

Fasade 1

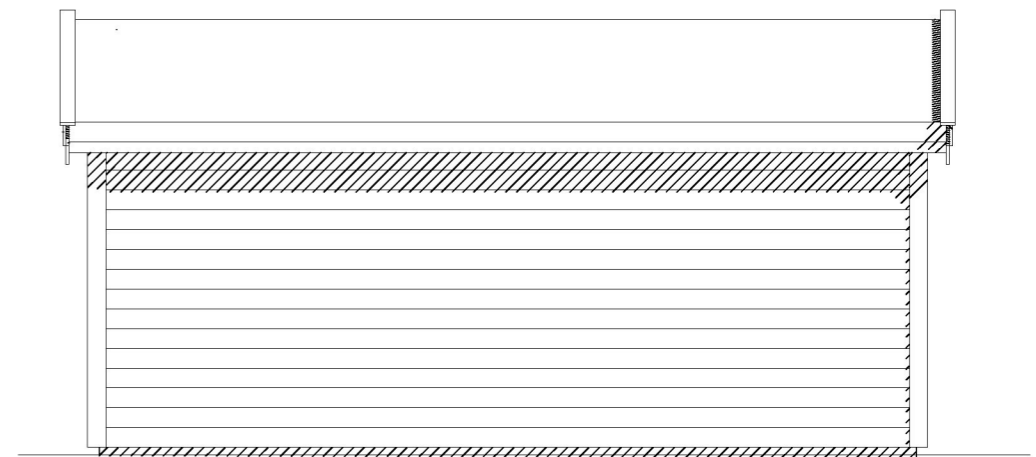

Fasade 2

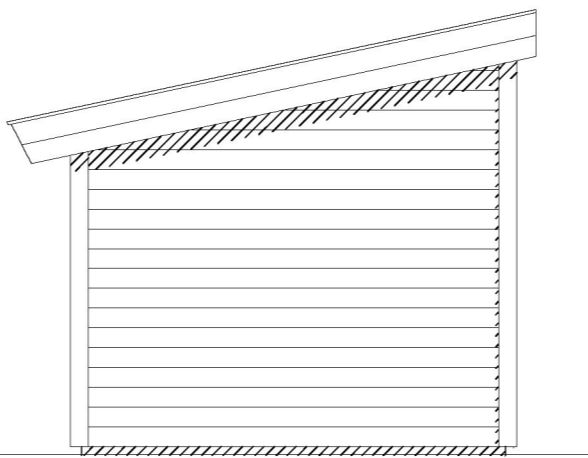

Fasade 3

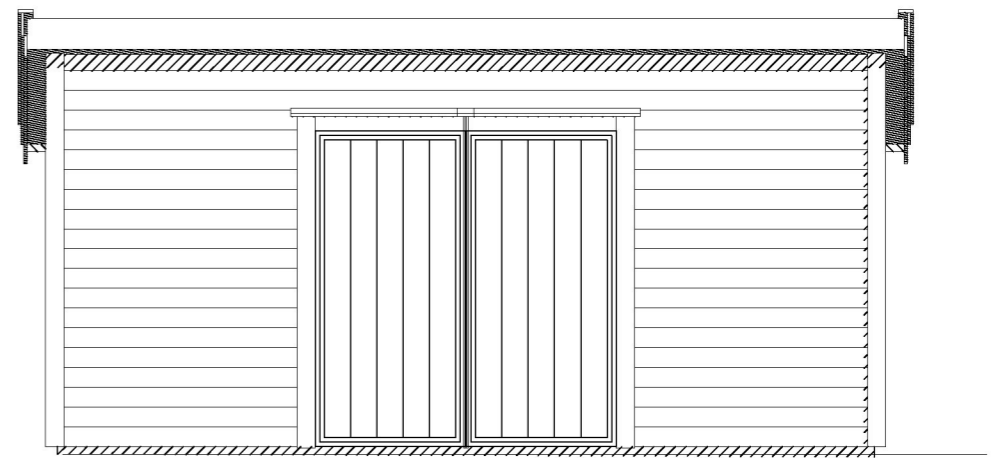

Fasade 4

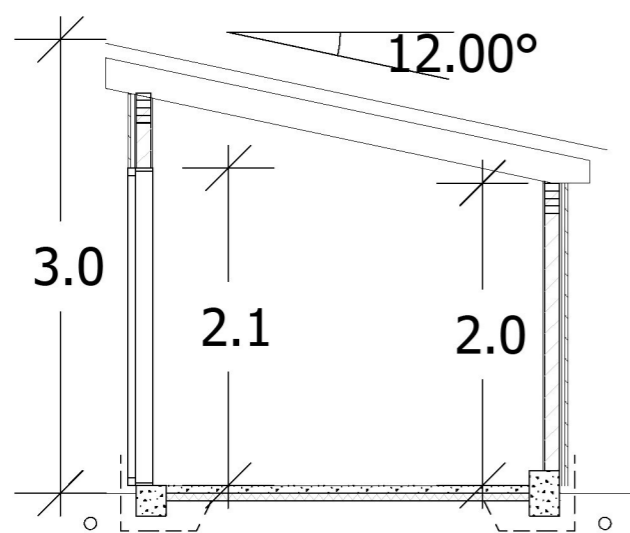

Snitt A-A



1 02.01.2023 Inga Utvidelse av bod.

DATA DESIGN SYSTEM

Arealberegninger i hht. NS 3940	Bruksareal BRA kvm	
	Utvendig bod/garasje	Sum BRA
1. etasje	13.4	13.4
SUM :	13.4	13.4
BYA :	15.1	15.1

Kvala Arkitekter

Tiltakshaver: **Svein Einar Reinertsen**

Byggeplass: **Postvegen 131, 4280 Skudeneshavn**

Kommune: **Karmøy**

Gnr: **43** Bnr: **538** Mål: **1 : 50**

Plan, snitt og fasader

Dato: **20.12.2022**

Tegn: **Inga**

Prosjekt: **3-1501222 bod**

Tegn.nr: **502**

© Tegningen er beskyttet i.h.t. lov om opphavsrett.